



# HYGEAR

EMBRACING TODAY'S INDUSTRIAL  
MARKETS TO BECOME A LEADER IN  
FUTURE ENERGY

MARINUS VAN DRIEL



# ABOUT HYGEAR

- Established in 2002
- Clean-tech company with unique competencies of small scale chemical processing and protected Intellectual Property
- Strong financial performance and autonomously financed
- Focused company (65 people) with benefits from strong shareholder ABENGOA S.A. (Spain) and PPM NV (NL)
- Local representation in Japan, Korea, Turkey and Russia



**ABENGOA**



# THE MERITS FOR OUR BUSINESS

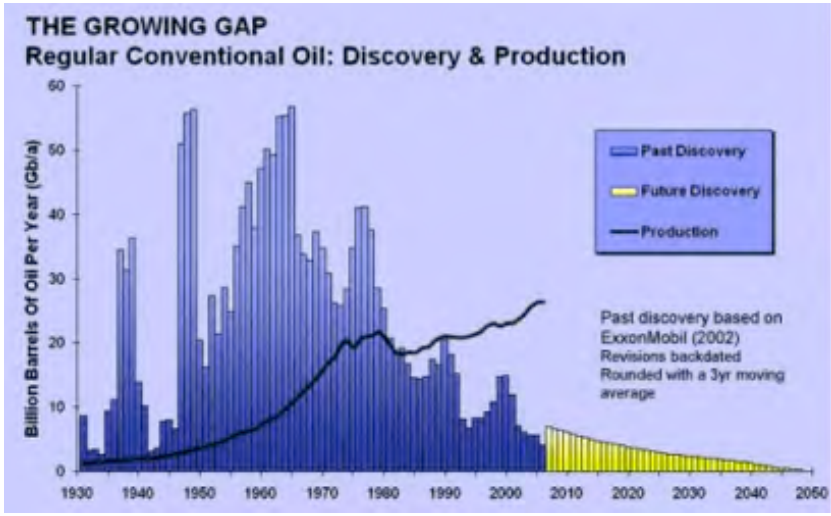



# THE END GAME: A HYDROGEN ECONOMY

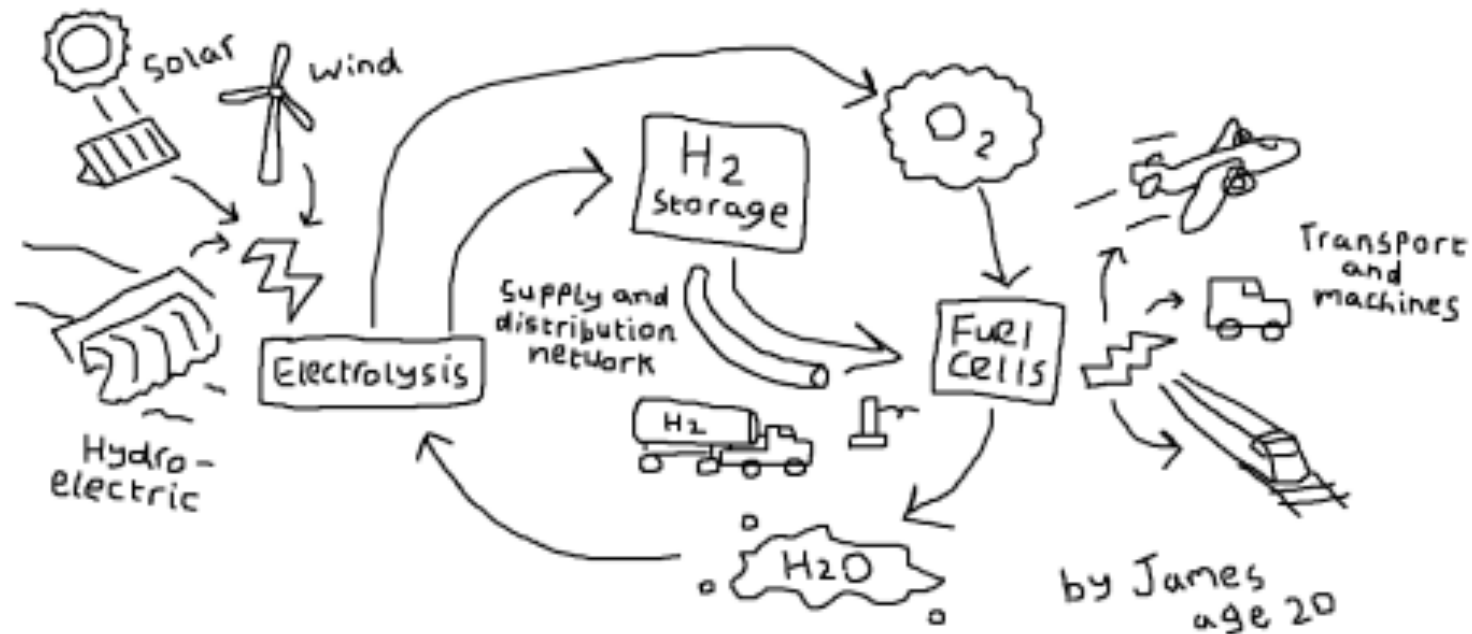

- But what about long term carbon based waste streams....
- ...and how do we match supply and demand.....
- ...and what to do with existing fossil sources.....

# OUR VISION: A NATURAL GAS BACKBONE

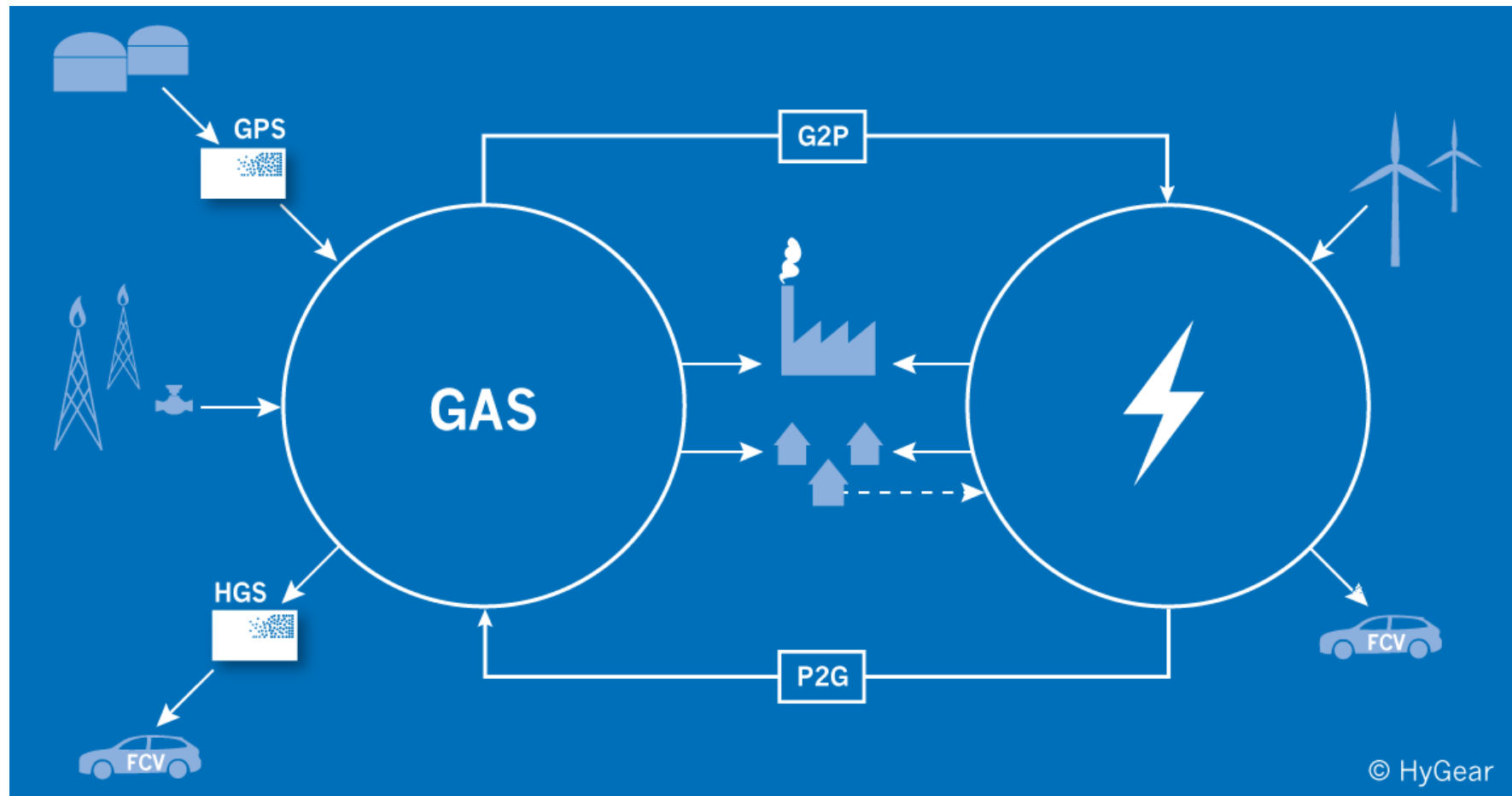

# CHARACTERISTICS

- Decentralized and small conversion technologies required
- Remaining issues
  - Optimal balance in capital deployed
  - Efficient fuel cells vs Inefficient electrolysis
  - Storage capacity gas network

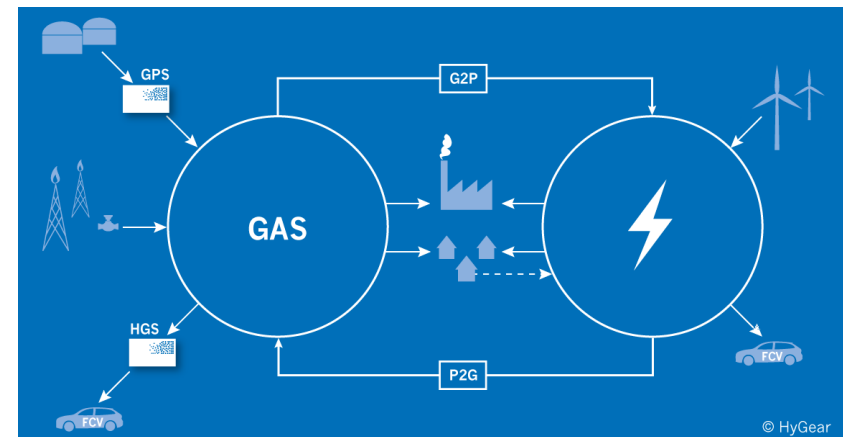
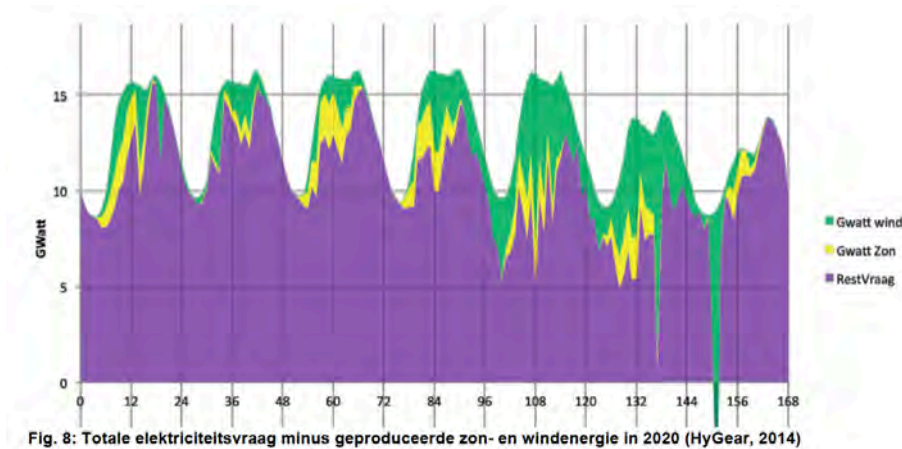

# OUR PRODUCT STRATEGY

“Embracing today's Industrial Markets to become a leading player in Future Energy Technologies”

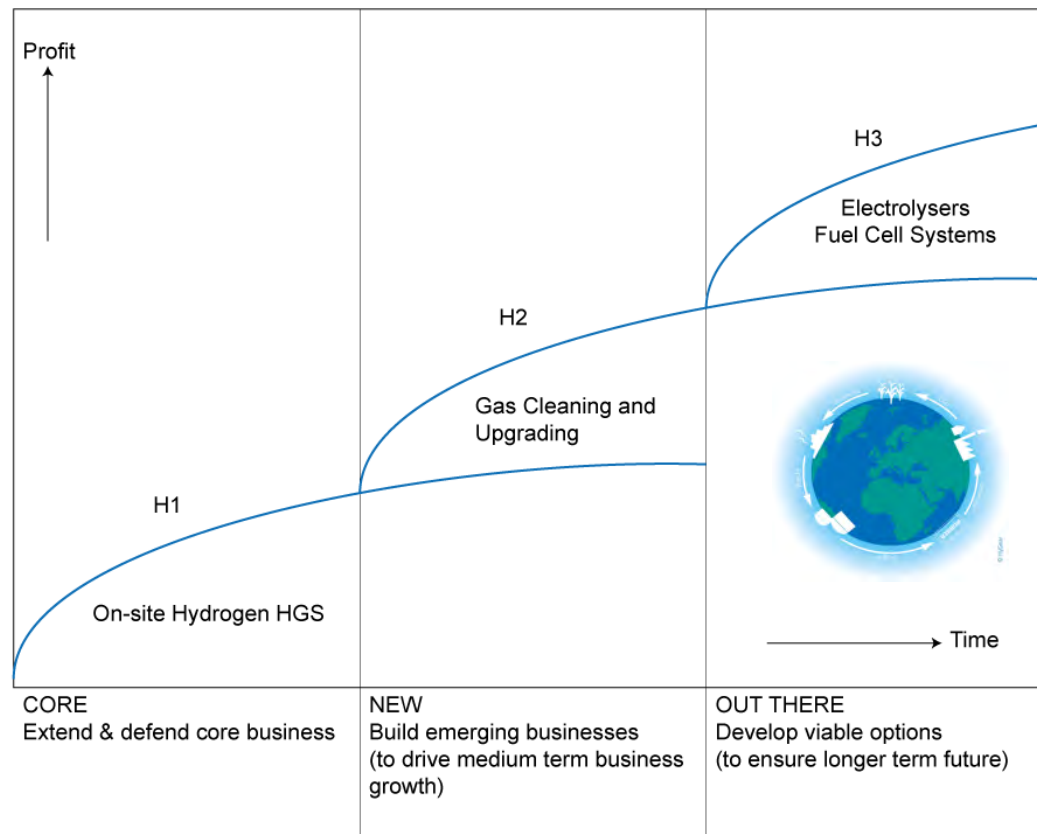



# HORIZON 1: ON SITE HYDROGEN





# PRODUCT SPECIFICS HYGEN (HGS)

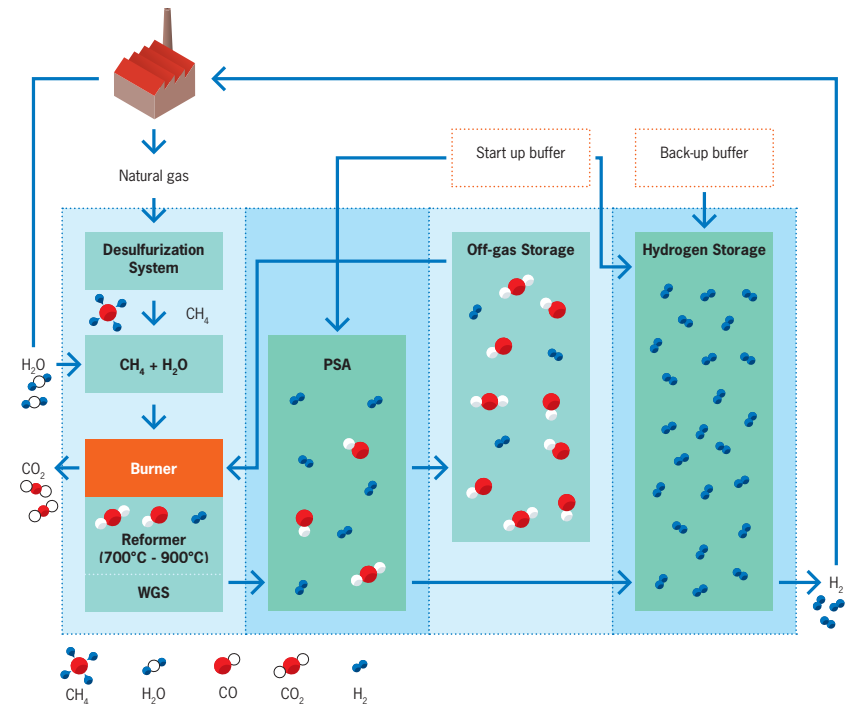
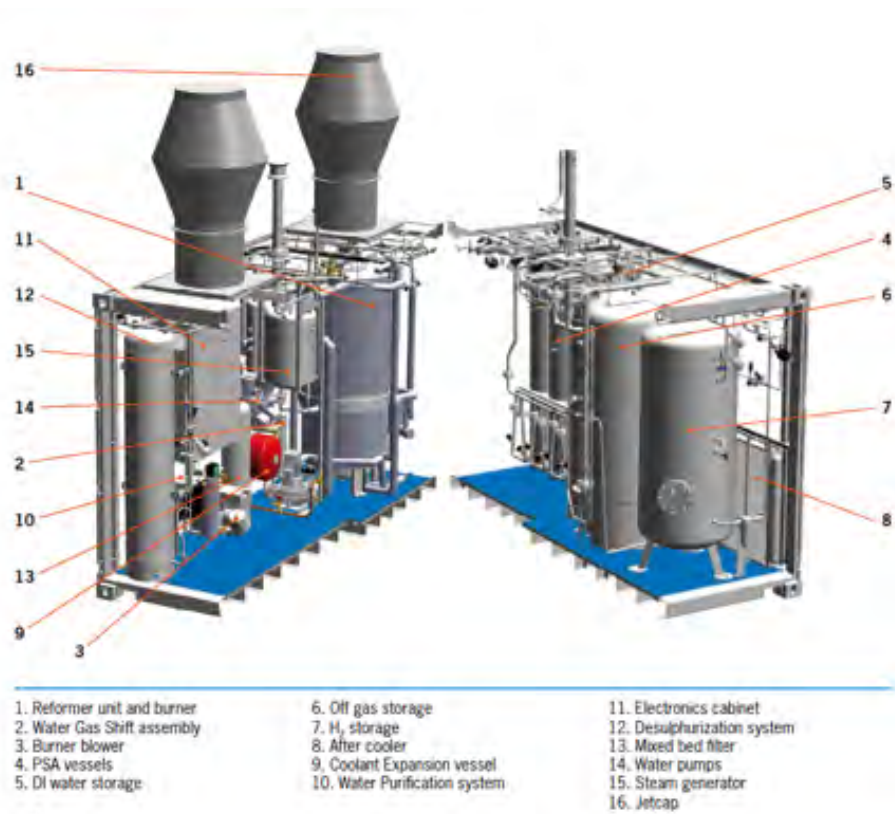

# VALUE PROPOSITION

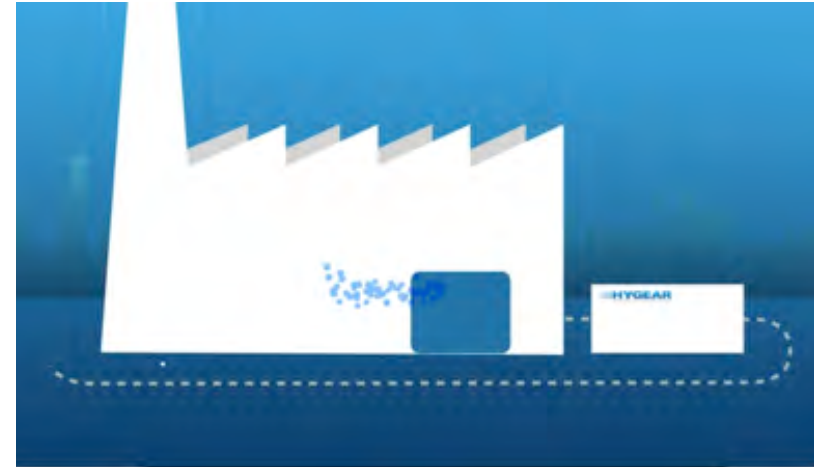
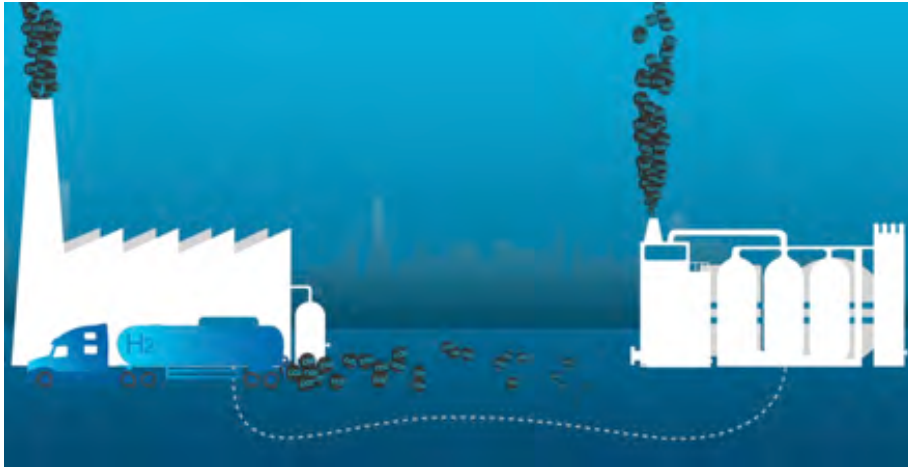

- Compression and transportation become obsolete
- Highly energy efficient technology
- Cost and energy savings in todays Industrial Markets Flat Glass, Steel, Food and semi-conductor
- Strong growth potential in Future Energy

# HORIZON 2: GAS PURIFICATION



December 14, 2014



# PRODUCT SPECIFICS PSA SYSTEMS

- Gas Separation by Hybridized Vacuum PSA systems with
- Today's Markets: On site recovery of Hydrogen Mixtures
- Cost savings in Industrial gas Markets Glass, Gas and Steel

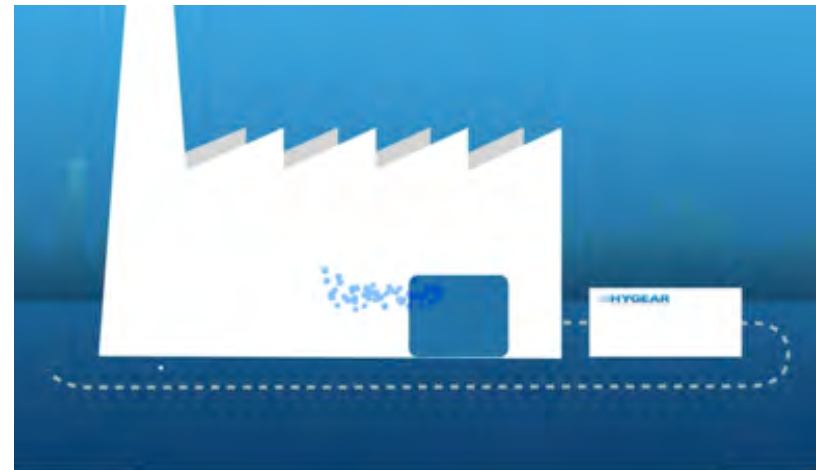
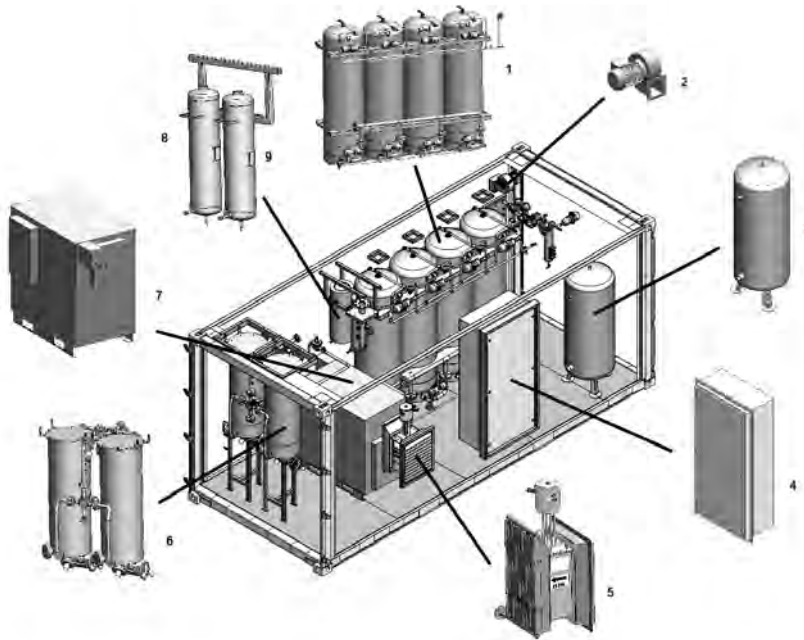



# FUTURE MARKETS: SNG PRODUCTION (WOBBERS)

- Upgrade gases from digesters or gasifiers (waste)
- Revolutionary concept to use part of the gas to generate inert and blend that into the gas stream
- Feed-in with the exact right composition

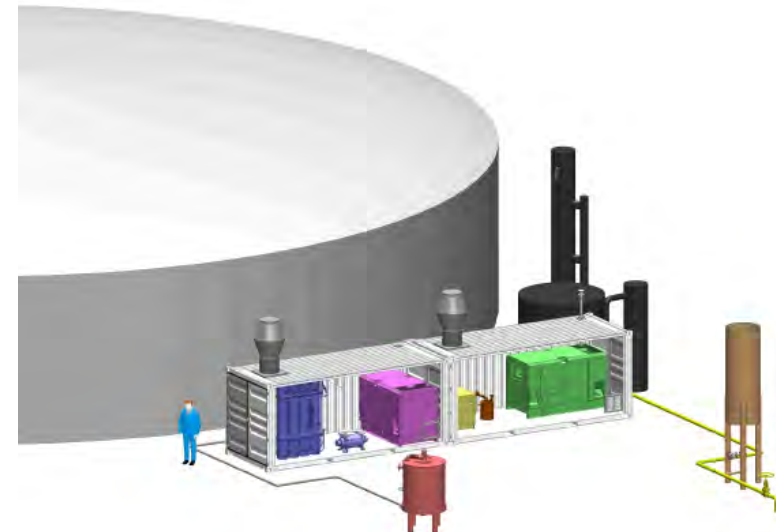
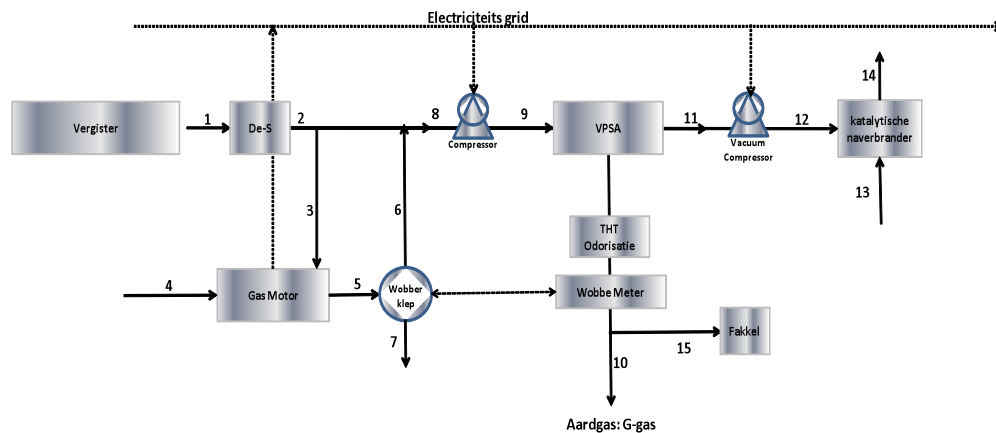

# FUTURE HORIZONS: FUEL CELL SYSTEMS AND REVOLUTIONARY ELECTROLYSIS



# DEVELOPMENT FOCUS, FUEL CELL SYSTEMS

## ELECTROLYSIS

- High temperature Electrolysis concept developed
- Early stage testing and development



## FUEL CELLS

- Strongest load balancing tool in the natural gas network
- Product development at HyGear in different sizes for PEM and SOFC based fuel cells
- Starting 2015, development continues with Dutch boiler OEM (ATAG) for commercial product





# CONCLUSIONS

- The natural gas network is a strong backbone for transition towards a sustainable energy system
  - Everybody is already connected (no divestments)
  - It allows for input all sources
  - Highly efficient storage capacity
- Still issues to be solved
  - GtP more efficient than PtG (better electrolysis needed)
  - Utilization of all available sources should become possible
  - The gas network needs to be able to store at all times
- Applications can be tested in Today's Industrial Markets
  - Generate Experience
  - Energy savings and cost savings realized
  - Revenue are generated and sustainable businesses can be built



# ENGINEERING FOR SUSTAINABLE GROWTH!

